

# HEALD®

## HT1 HYDRAULIC VIPER

Heald's Viper offers a shallow mount solution to sites that require the protection of a Roadblocker, but cannot excavate at depth due to utilities or drainage issues.

The unique design of the Viper includes a sacrificial safety skirt to protect the internal components and reduce trap hazards associated with an open wedge barrier. The skirt is designed for easy access for maintenance and reduced debris build up, with a smooth and quiet operation.

The Viper can be integrated with various access control systems to provide quick and convenient access to authorised vehicles and emergency services. For the highest security sites, the Viper is available with Emergency Fast Operation (EFO), which raises the wedge in less than 2 seconds for immediate protection against an imminent threat to the site.

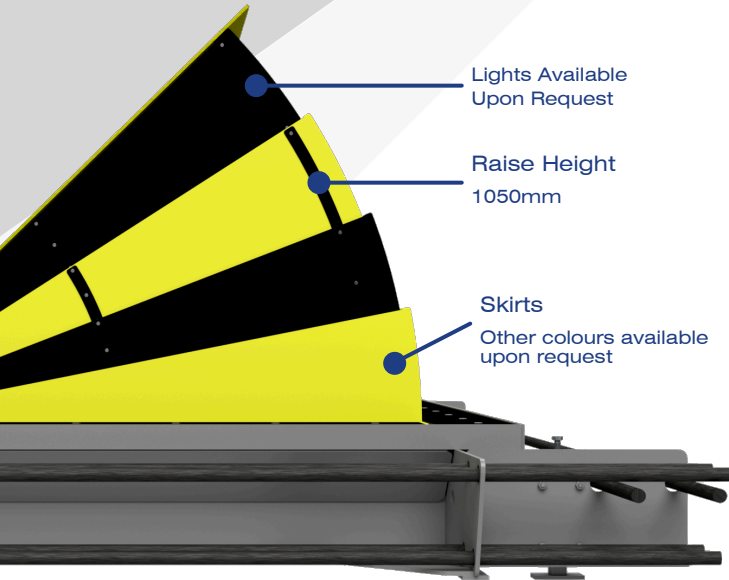

### Crash Test Results

The Viper has been tested to meet both UK and US standards.

Halted a 7.5 tonne vehicle travelling at 80kph with zero penetration and continued to operate after impact.

#### Classification

PAS68:2010 V/7500[N3]/80/90:0/24.6

ASTM 2656-07 M50:P1



### Operation

A 3kW HPU driven mechanism with manual hand pump for power fail.

Operated via a single hydraulic cylinder, providing smooth operation and easier servicing and maintenance.

The Viper also has proven reliability as an installed product and through in-house longevity testing.

415VAC Three phase, earth & neutral, 50Hz Alternatives available to suit site requirements.

### Safety Features Available

Induction Loops & Sacrificial Skirts.

### Operating Speeds

Standard Operation: 6 seconds approx

EFO Operation: 1.5 seconds approx (optional)

### Installation

The unique design means that no pre-cast pit or additional rebar is required for installation.

The Viper comes with integral levelling feet and rebar fitting kit for flexibility during install to suit the ground conditions.

### Options

Emergency Fast Operation (EFO), LED lights, High security lock-out valve and various access controls available.

### Please contact for further details:

01964 535858  
www.heald.uk.com  
sales@heald.uk.com  
© Heald Ltd 2010

# HEALD®

## HT1 HYDRAULIC VIPER CONFIGURATIONS

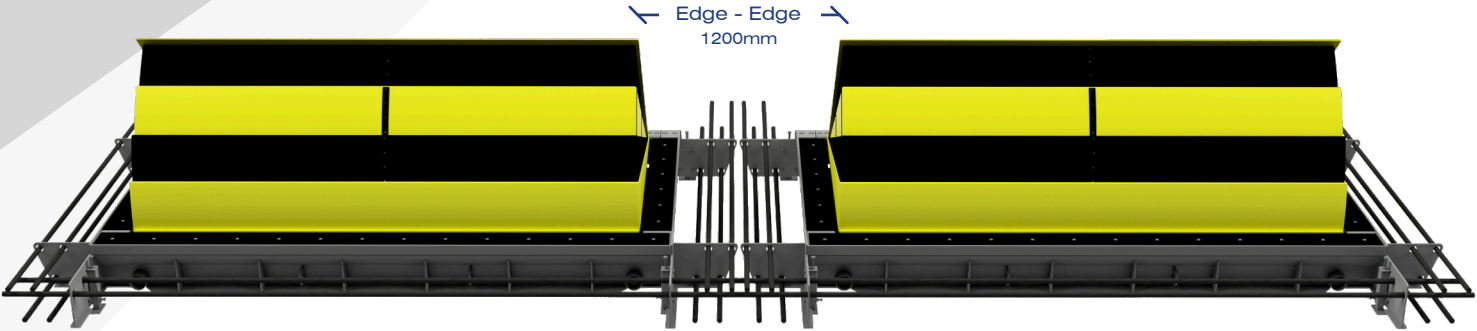

Arrays in excess of 2 Vipers and gaps less than 1200mm between blockers can also be achieved - contact Heald for details.  
Viper array of 2 shown above.

The Viper was tested at 3000mm width, securing an opening of up to 5400mm Widths available shown below.	
<b>Viper 1.8m</b>	
<b>Viper 2.5m</b>	
<b>Viper 3.0m</b>	
<b>Viper 3.5m</b>	
<b>Viper 4.0m</b>	

<b>Roadblocker Spacing</b>
HT1 Viper Roadblockers are spaced at 1200mm edge to edge.
<b>Standard Finish</b>
Galvanised, primed and painted black and yellow. (Other colours available upon request).
<b>Axle Loadings</b>
20 tonnes per axle (up to 120 tonnes for a 6 axle vehicle).
<b>Base Depth / Excavation Depth</b>
340mm base 380mm excavation
<b>Foundation Details</b>
Please refer to/request an installation drawing.

**Please contact for further details:**

01964 535858  
www.heald.uk.com  
sales@heald.uk.com  
© Heald Ltd 2010

